

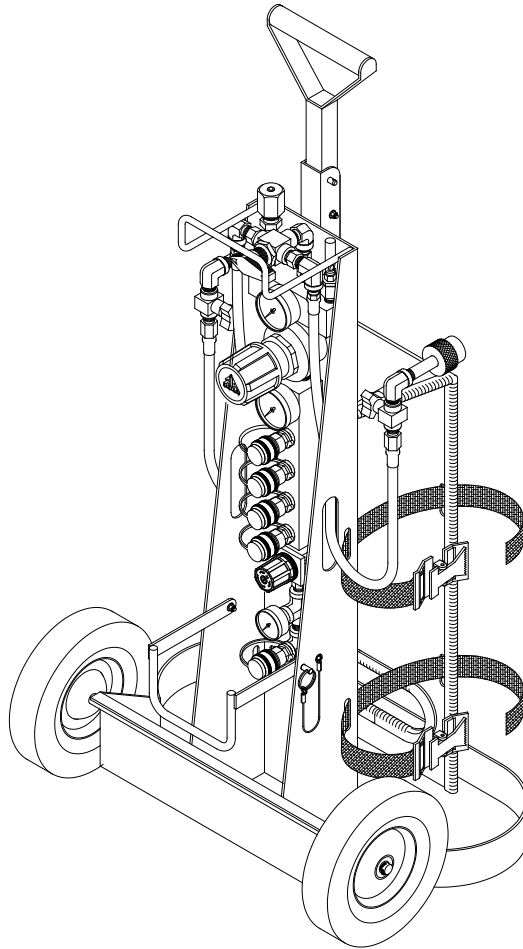

OPERATING INSTRUCTIONS AND REPLACEMENT PARTS

Models: MP-4R and MP-4RSS



WARNING

This manual must be read carefully and followed by all persons who have or will have the responsibility for using or servicing this equipment. This equipment will perform as designed only if used according to the instructions. Otherwise it could fail to perform as designed, causing personal injury or death.

AIR SYSTEMS INTERNATIONAL, INC.

829 Juniper Crescent, Chesapeake, Va, 23320

Telephone (757) 424-3967

Toll Free 1-800-866-8100

Fax No. (757) 424-5348

www.airsystems.com.

e-mail: sales@airsystems.com

Specifications

Size	35"H X 20.5"W X 15"D (Handle Collapsed)
Weight	41 Lbs. Without Cylinders
Frame Material	Powder-Coated Steel (MP-4R) / Stainless Steel (MP-4RSS)
Whip Assemblies	Thermo-Plastic Hose Rated @ 5000 PSI (345 BAR) with a 4:1 Safety Factor
Low Pressure Alarm	Whistle Set @ 500 PSI (34.5 BAR)
Primary Regulator	5500 PSI (379 BAR) Max Inlet / 125 PSI (8.6 BAR) Max Outlet Flow Rate is 80 CFM (2260 LPM) @ 125 PSI (8.6 BAR)
Secondary Regulator	300 PSI (20.6 BAR) Max Inlet / 125 (8.6 BAR) Max Outlet Max Flow Rate is 14 CFM (396 LPM) @ 100 PSI (6.9 BAR) Inlet / 70 PSI (4.8 BAR) Outlet
Relief Valve	ASME Preset @ 125 PSI (8.6 BAR)
Intrinsically Safe	Yes

Setup And Operation

STEP 1)

Install cylinders on cart. Secure cylinders by tightening the straps at the buckle and mate the velcro sections to prevent slipping. 2216 PSI (153 BAR), 4500 PSI (310 BAR), or 5500 PSI (380 BAR) cylinders can be used.

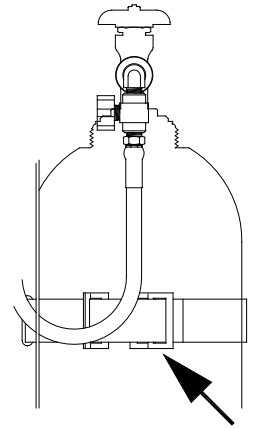

STEP 2)

Install the universal CGA-347 hand-tight nuts to the cylinder valves and tighten. Close both bleeder valves by turning their knobs fully clockwise.

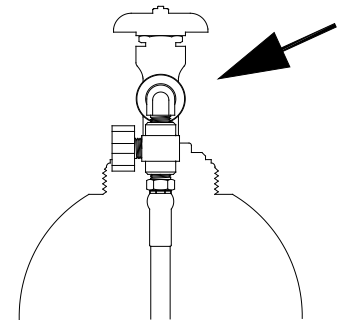

STEP 3)

Open one cylinder and index the selector valve so the knob points towards the open cylinder. At this time the low pressure whistle will sound until pressure reaches approximately 1000 PSI (69 BAR). Check reading on gauge to verify cylinder is full. Close the cylinder.

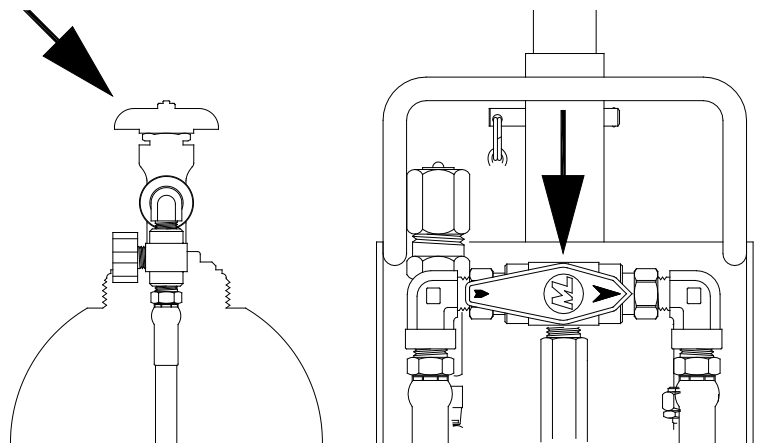

Setup And Operation

STEP 4) LOW PRESSURE ALARM TEST

Set the required respirator pressure by turning the regulator knob clockwise to increase pressure or counter-clockwise to decrease pressure. Bleed pressure from the system by partially engaging a male plug in one of the respirator couplings. This depressurizes the system and simulates low cylinder pressure. The low pressure whistle will sound at approximately 500 PSI (35 BAR).

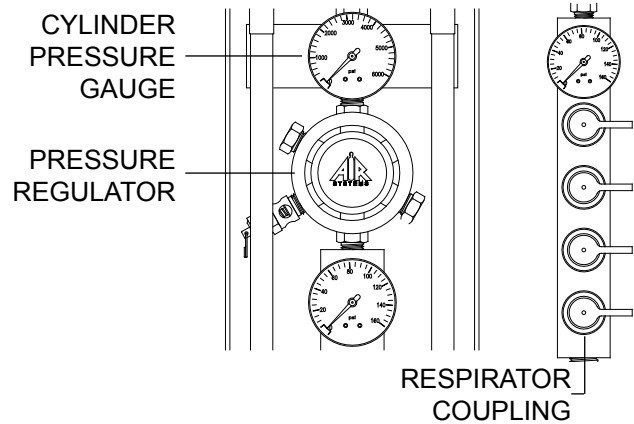

STEP 5)

Index the selector valve toward the other cylinder and open the cylinder valve. At this time the low pressure warning alarm will sound until approximately 1000 PSI (69 BAR). Check reading on gauge to verify cylinder is full.

STEP 6) OPTIONAL

Install high pressure connect whip to auxiliary inlet port (CGA-347). This step can be done anytime during the operation of the system. The auxiliary inlet port is not controlled by the selector valve. It directly feeds the regulator.

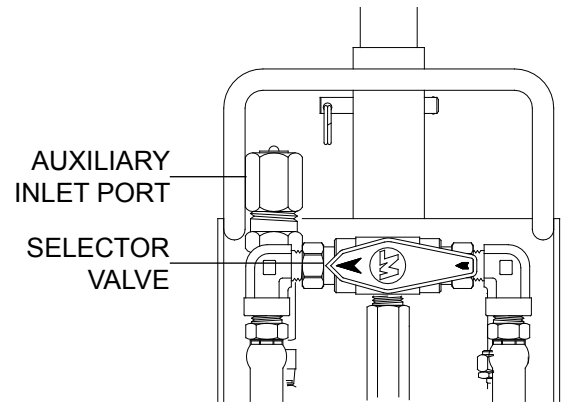

STEP 7)

Connect hose(s) and respirator(s) to the respirator coupling(s) and readjust pressure if necessary.

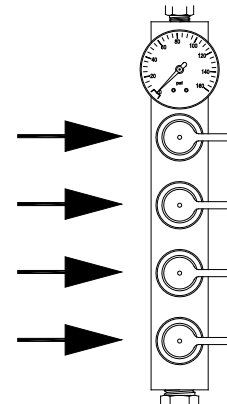

STEP 8) OPTIONAL

If a device is needed that requires a different pressure than the devices connected to the manifold; connect device to coupling and set the secondary regulator to the required pressure by pulling knob out to unlock and turn knob clockwise to increase pressure or counterclockwise to decrease pressure. Push regulator knob in to lock regulator. Max. flow thru the secondary regulator is 14 CFM (396 LPM) @ 100 PSI (6.9 BAR) Inlet / 70 PSI (4.8 BAR) Outlet

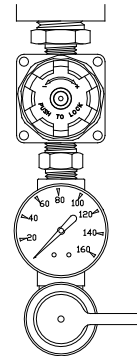

Cylinder Change

When the cylinder in use has been depleted to approximately 500 PSI (35 BAR), the low pressure warning alarm will sound indicating the cylinder needs to be replaced. To change a cylinder while the cart is in use:

STEP 1)

Index the selector valve knob towards the full cylinder.

STEP 2)

Check the incoming pressure gauge to verify cylinder is full.

STEP 3)

Close the spent cylinder and open the bleeder valve to relieve pressure on the hand-tight nut.

STEP 4)

Remove the drained cylinder and replace it with a full cylinder. Connect the CGA-347 hand-tight nut to the cylinder valve and close the bleeder valve.

Shutdown

Make sure all personnel have egressed the hazardous area and have disconnected from the breathing air system.

1. Close cylinder valves.
2. Depressurize manifold pressure by pulling the relief valve ring.
3. Close the regulator by turning the control knob counterclockwise.
4. Disconnect airline hose(s) and reinstall dust cap(s).
5. Remove connections from cylinders and reinstall cylinder valve covers (if applicable).

High Pressure Airline Maintenance and Inspection

Monthly:

1. Check regulators, gauges, and valves for external leakage.
2. Inspect cylinder valves for proper closure.
3. Check cylinder pigtails for cleanliness, flexibility, wear, leakage, blisters on the hose, thread damage and o-rings on CGA fittings. Replace damaged/missing items immediately.

Annually:

1. Check relief valve's pressure setting.
2. Check regulator function by opening and closing regulator valve knob fully.

System Components

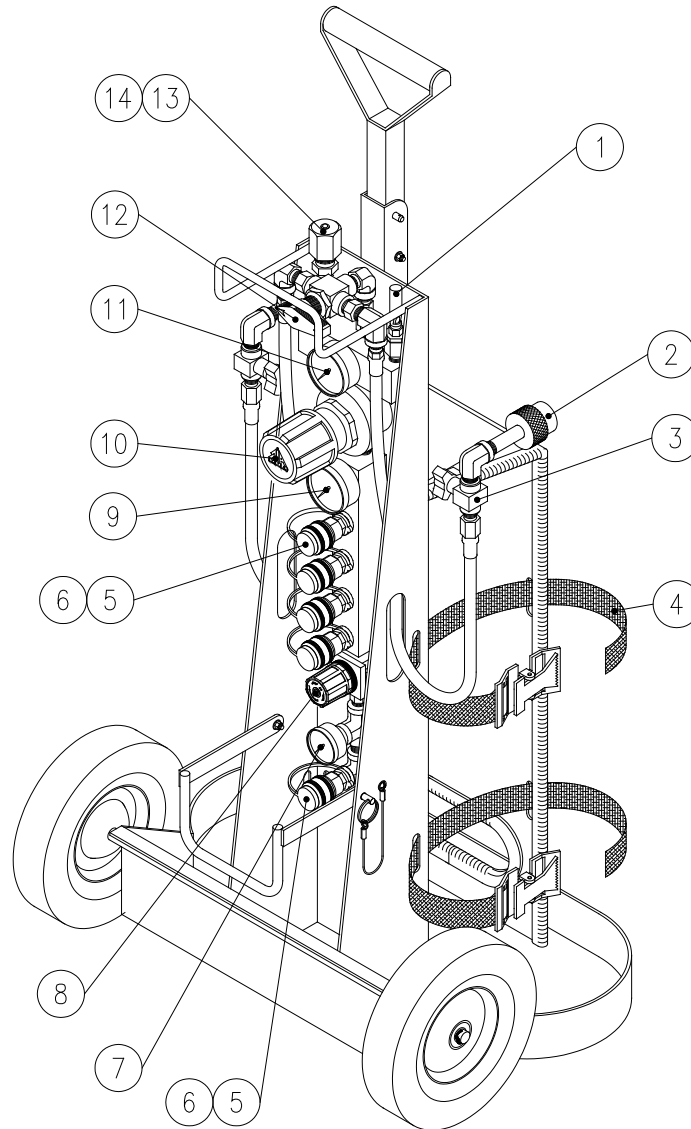

ITEM #	DESCRIPTION	PART #
1	LOW PRESSURE WHISTLE	AC-PA25
2	CGA-347 HAND-TIGHT NUT/STEM	SS347HT
3	BLEEDER VALVE	VAL030
4	CYLINDER STRAP	HDWR113A
5	HANSEN COUPLING	QDH3SL4M
5A	SCHRADER COUPLING	QDSSL4M
6	HANSEN DUST CAP	QDH3DCAP
6A	SCHRADER DUST CAP	QDSDCAP
7	SECONDARY OUTLET PRESSURE GAUGE	GA15160B
8	SECONDARY PRESSURE REGULATOR	WL013
9	OUTLET PRESSURE GAUGE	GA20160B
10	PRESSURE REGULATOR	REG-5000NG
11	INLET PRESSURE GAUGE	GA2075KB
12	SELECTOR VALVE	VAL153
13	AUXILIARY INLET PORT	SS4F347AM
14	PRESSURE CAP	SS347CAP

Warranty

Air Systems' manufactured equipment is warranted to the original user against defects in workmanship or materials under normal use for one year from the date of purchase. Any part which is determined by Air Systems to be defective in material or workmanship will be, as the exclusive remedy, repaired or replaced at Air Systems' option. This warranty does not apply to electrical systems or electronic components. Electrical parts are warranted, to the original user, for 90 days from the date of sale. During the warranty period, electrical components will be repaired or replaced at Air Systems' option.

NO OTHER WARRANTY, EXPRESSED OR IMPLIED, AS TO DESCRIPTION, QUALITY, MERCHANTABILITY, FITNESS FOR A PARTICULAR PURPOSE, OR ANY OTHER MATTER IS GIVEN BY AIR SYSTEMS IN CONNECTION HERewith. UNDER NO CIRCUMSTANCES SHALL THE SELLER BE LIABLE FOR LOSS OF PROFITS, ANY OTHER DIRECT OR INDIRECT COSTS, EXPENSES, LOSSES, OR DAMAGES ARISING OUT OF DEFECTS IN, OR FAILURE OF THE PRODUCT OR ANY PART THEREOF.

The purchaser shall be solely responsible for compliance with all applicable Federal, State and Local OSHA and/or MSHA requirements. Although Air Systems International believes that its products, if operated and maintained as shipped from the factory and in accordance with our "operations manual", conform to OSHA and/or MSHA requirements, there are no implied or expressed warranties of such compliance extending beyond the limited warranty described herein. Product designs and specifications are subject to change without notice. Rev. 2, 12/98

Air leaks are not covered under warranty except when they result from a defective system component, i.e. an on/off valve or regulator or upon initial delivery due to poor workmanship. Air leaks due to poor delivery or damage will be covered under delivery claims. Minor air leaks are part of routine service and maintenance and are the responsibility of the customer just as are filters and oil changes.

